

## RESEARCH ARTICLE

# Migration- and exercise-induced changes to flight muscle size in migratory birds and association with *IGF1* and *myostatin* mRNA expression

Edwin R. Price<sup>1,\*</sup>, Ulf Bauchinger<sup>2</sup>, Daria M. Zajac<sup>1</sup>, David J. Cerasale<sup>3</sup>, Jay T. McFarlan<sup>4</sup>, Alexander R. Gerson<sup>1</sup>, Scott R. McWilliams<sup>2</sup> and Christopher G. Guglielmo<sup>1</sup>

<sup>1</sup>Advanced Facility for Avian Research, Department of Biology, University of Western Ontario, London, ON, Canada, N6A 5B7,

<sup>2</sup>Department of Natural Resources Science, University of Rhode Island, Kingston, RI 02881, USA, <sup>3</sup>Department of Ecology and Evolutionary Biology, Cornell University, Ithaca, NY 14853, USA and <sup>4</sup>Department of Human Health and Nutritional Sciences,

University of Guelph, Guelph, ON, Canada, N1G 2W1

\*Author for correspondence (eprice2@uwo.ca)

Accepted 24 May 2011

### SUMMARY

Seasonal adjustments to muscle size in migratory birds may result from preparatory physiological changes or responses to changed workloads. The mechanisms controlling these changes in size are poorly understood. We investigated some potential mediators of flight muscle size (myostatin and insulin-like growth factor, IGF1) in pectoralis muscles of wild wintering or migrating white-throated sparrows (*Zonotrichia albicollis*), captive white-throated sparrows that were photoperiod manipulated to be in a 'wintering' or 'migratory' (Zugunruhe) state, and captive European starlings (*Sturnus vulgaris*) that were either exercised for 2 weeks in a wind tunnel or untrained. Flight muscle size increased in photo-stimulated 'migrants' and in exercised starlings. Acute exercise but not long-term training caused increased expression of IGF1, but neither caused a change in expression of myostatin or its metalloprotease activator TLL1. Photo-stimulated 'migrant' sparrows demonstrated increased expression of both myostatin and IGF1, but wild sparrows exhibited no significant seasonal changes in expression of either myostatin or IGF1. Additionally, in both study species we describe several splice variants of myostatin that are shared with distantly related bird species. We demonstrate that their expression patterns are not different from those of the typical myostatin, suggesting that they have no functional importance and may be mistakes of the splicing machinery. We conclude that IGF1 is likely to be an important mediator of muscle phenotypic flexibility during acute exercise and during endogenous, seasonal preparation for migration. The role of myostatin is less clear, but its paradoxical increase in photo-stimulated 'migrants' may indicate a role in seasonal adjustments of protein turnover.

Key words: avian, TLL1, muscle size, hypertrophy, phenotypic flexibility, splice variant, Zugunruhe, myostatin, IGF1.

### INTRODUCTION

Bird migration is a phenomenon involving extensive changes in physiology and form, including changes to oxidative capacity, hormone levels and sensitivity, fat storage and individual organ sizes (Marsh, 1984; Dietz et al., 1999; Landys et al., 2004a; McFarlan et al., 2009). Flight muscles in particular could be expected to increase in size in anticipation of, or in response to, the increased muscle loading and exercise associated with migration. Indeed, pectoralis muscle mass increases during the premigration period (Evans et al., 1992; Driedzic et al., 1993; Battley and Piersma, 1997; Bauchinger and Biebach, 2006), even in captive birds without training, although not to the same extent as in free-living migrants (Dietz et al., 1999; Vézina et al., 2007). Within the migratory season, flight muscles also fluctuate in size. During a migratory flight, muscles may decrease in size to adaptively match lighter loads (as fat is oxidized) (Lindström et al., 2000), as muscles are catabolized for energy, citric acid cycle intermediates or water (Biebach, 1998; Battley et al., 2000; Lindström et al., 2000; Bauchinger and Biebach, 2001; Bauchinger et al., 2005; Gerson and Guglielmo, 2011), or simply as a result of protein turnover (Bauchinger and McWilliams, 2010). Muscles must then be rebuilt before the next migratory flight, and flight muscles are known to increase in size during migratory

stopover periods (Biebach, 1998; Piersma et al., 1999; Bauchinger and Biebach, 2001; Landys-Ciannelli et al., 2003). Exercise training itself can also result in muscular hypertrophy (Butler and Turner, 1988). Although these seasonal and flight-related changes in muscle size have been documented, very little is known about how these changes are coordinated and controlled.

Myostatin and insulin-like growth factor 1 (IGF1) are important mediators of muscle growth, and their transcription may be central to the modulation of adult mammalian muscle size (Rennie et al., 2004). Myostatin is primarily expressed in muscles in mammals, although it has been found in some other mammalian tissues, and is expressed in many tissues from other vertebrates (reviewed by Rodgers and Garikipati, 2008). Following translation, secretion and some proteolytic processing of myostatin, an inhibitory propeptide is cleaved by a metalloprotease such as tollid-like protein 1 (TLL-1) to produce the mature myostatin protein (Lee, 2004). This activated myostatin can enter the circulation or act locally, and inhibits muscular growth by inhibiting differentiation of satellite cells and by altering the protein synthesis/degradation environment of myocytes (Lee, 2004). These last effects have been hypothesized to act *via* either decreased protein synthesis or increased protein degradation (Taylor et al., 2001; McFarlane et al., 2006; Amirouche

et al., 2009). Myostatin can increase protein degradation by upregulation of the ubiquitin proteolytic system (McFarlane et al., 2006), and this is further supported by the effects of the myostatin propeptide (Zhao et al., 2009). Decreased protein synthesis can occur by inhibition of the mammalian target of rapamycin (mTOR) pathway (Amirouche et al., 2009), which is a target for upregulation by the IGF1 signalling pathway and controls protein synthesis. The negative regulation of muscle size by myostatin has been demonstrated in mammals, particularly during development (McPherron et al., 1997). In adult mammals, exercise training can result in muscle growth that is associated with decreased myostatin mRNA and protein expression (Matsakas et al., 2005; Matsakas et al., 2006; Louis et al., 2007).

IGF1 is expressed primarily in liver in response to growth hormone, but is also expressed in muscles in response to muscle contraction, growth hormone and other factors. IGF1 is secreted and binds to IGF1 receptors (IGFR) in muscles in an autocrine or paracrine manner, stimulating pathways leading to differentiation, proliferation and anabolism (Adams, 1998). Like myostatin, IGF1 has been proposed to regulate mammalian muscle size in response to exercise and muscle loading (DeVol et al., 1990; Adams, 1998; Rennie et al., 2004; Heinemeier et al., 2007; Choi et al., 2009). In birds (primarily from studies in embryonic or neonate poultry), myostatin and IGF1 similarly appear to have functions in mediating muscle hypertrophy and hyperplasia during development (Guernec et al., 2003; Duclos, 2005; Sato et al., 2006; Kim et al., 2007; McFarland et al., 2007). Further, a previous study documented increases in pectoralis muscle mass in the non-migratory house sparrow (*Passer domesticus*) during the winter that were associated with decreases in *myostatin* mRNA and *TLL-1* mRNA in pectoralis muscle, suggesting that the myostatin pathway might control seasonal changes in adult avian muscle size (Swanson et al., 2009). These studies prompted us to investigate the possibility that *myostatin* or *IGF1* could be involved in the regulation of muscle size during avian migration and exercise.

In this study, we examined changes in pectoralis muscle mRNA expression of *myostatin* and *IGF1* in three avian contexts. First, to investigate overall seasonal changes associated with migration, we compared white-throated sparrows (*Zonotrichia albicollis* Gmellin) at wintering grounds to those captured during migration at a stopover site. Second, to investigate endogenous control associated with the migratory season without the confounding effect of exercise, we also compared two groups of captive white-throated sparrows that were photoperiod manipulated to be in either a 'wintering' or a 'migrant' (Zugunruhe) state. Third, we examined the effects of exercise training and acute exercise in European starlings (*Sturnus vulgaris* L.) flown in a wind tunnel. We predicted that muscle size would be greater in 'migrant' and exercised birds, and that this would be associated with an increase in *IGF1* expression and a decrease in *myostatin* expression. Additionally, in the course of our research we found several splice variants of *myostatin* and we investigated the possible functionality of these variant transcripts.

## MATERIALS AND METHODS

### Animals and experimental manipulations

White-throated sparrows (*Z. albicollis*) are short-hop migrants that winter primarily in the south eastern United States and breed in the north eastern United States and in Canada. We caught white-throated sparrows that were overwintering in Mississippi in January ( $N=18$ ) as well as sparrows that were migrating through southern Ontario in both autumn ( $N=36$ ) and spring ( $N=17$ ) [described previously by

McFarlan et al. (McFarlan et al., 2009)]. These sparrows were caught in the morning with mist-nets, and killed immediately after capture by cervical dislocation under brief (<1 min) isoflurane anaesthesia; a sample of the left pectoralis muscle was immediately removed and stored in liquid nitrogen until transfer to a  $-80^{\circ}\text{C}$  freezer (for quantitative PCR, qPCR). Muscle mass was not measured in these sparrows. Autumn sparrows were aged according to the degree of skull ossification (Pyle, 1997).

Another set of white-throated sparrows was captured during autumnal migration in southern Ontario and kept in captivity at  $21^{\circ}\text{C}$  on a short day photoperiod (8 h L:16 h D). White-throated sparrows take to captivity well, and sparrows maintained healthy masses (generally over 20 g) for the duration of the experiment. After 60 days, half of the birds were switched to a long day ('migratory',  $N=24$ ) photoperiod (16 h L:8 h D) in order to stimulate Zugunruhe (migratory restlessness), a captive analogue of migratory condition (King and Farner, 1963; Landys et al., 2004b), while the other half were maintained on short days ('winter',  $N=24$ ). Both groups were maintained another 3–4 weeks before sampling, following the protocol of Landys et al. (Landys et al., 2004b). The long day group displayed nightly activity typical of Zugunruhe (Zajac, 2010). These birds were part of another experiment investigating the effects of leptin administration (Zajac, 2010), and most sparrows of both photoperiod groups were injected with leptin or phosphate-buffered saline in the week before sampling. Preliminary statistical analyses demonstrated that injection treatment had no effect on the expression of genes measured in the current study (ANOVA,  $P>0.528$  for both genes), so injection groups are pooled here. Sparrows were killed by cervical dislocation under brief isoflurane anaesthesia (2–5 h after lights on) and a sample of the left pectoralis muscle was collected as above, and carcasses were stored at  $-20^{\circ}\text{C}$  until later measurement of muscle mass. Tarsus length was measured post mortem with digital callipers.

The pectoralis muscle is the primary down-stroke muscle and accounts for about 90% of flight muscle mass, while the supracoracoideus lifts the wing during the upstroke. For determining muscle mass in captive white-throated sparrows, we dissected out the pectoralis and supracoracoideus muscles together because these muscles are often considered together as 'flight muscle' and are difficult to separate once frozen and thawed. Flight muscles removed from carcasses were weighed, dried at  $70^{\circ}\text{C}$  and then reweighed. Muscle masses were then corrected for the mass of the sample that was previously removed for qPCR by assuming an equal percentage of water in the sample.

European starlings (*S. vulgaris*) were introduced to North America and are now widespread there; they are thought to be mostly migratory in the Great Lakes region (Cabe, 1993). We used starlings for our exercise experiment because they can be trained relatively quickly to fly in a wind tunnel. We captured adult starlings in southern Ontario ( $43.17^{\circ}\text{N}$ ,  $-81.32^{\circ}\text{E}$ ) in July and kept them in indoor aviaries until September, when they were randomly assigned to three treatment groups (defined below). Two groups of starlings were trained to fly in a wind tunnel over a 2 week period with flights at  $15^{\circ}\text{C}$  and  $12\text{ms}^{-1}$  wind speed. Previous studies in *Sturnus* demonstrated that this training schedule resulted in excellent success (>80%) in eliciting long-duration flights in a short time period (Engel et al., 2006). The schedule was as follows: day 1, 10 min; day 2, 10 min; day 3, 20 min; day 4, 30 min; day 5, 30 min; day 6, 45 min; day 7, 60 min; day 8, 90 min; day 9, 30 min; day 10, 120 min; day 11, 180 min; day 12, no flight training; day 13, 15 min; day 14, 15 min. This training period was concluded (day 15) with a flight lasting as long as the birds would voluntarily fly (up to 4 h). One

Table 1. Degenerate and qPCR primers for *myostatin* (*MSTNa*), *myostatin* splice variants (*MSTNb–e*), *IGF1* and *TLL1* in white-throated sparrows (*Zonotrichia albicollis*) and European starlings (*Sturnus vulgaris*)

Gene	Forward primer and reverse primer	GenBank accession no.
<i>Myostatin</i> degenerate 1	5'-CCTGGAACAGCwCCdAACATyAGC-3' 5'-CAyTCTCrGAGCArTAATsGCTTTTrTA-3'	
<i>Myostatin</i> degenerate 2	5'-ATCCTCAGyAAACTGCGyCT-3' 5'-CACTCTCCAGAGCAGTAATTGkCCTTrTA-3'	
<i>MSTNa</i> *	5'-GGTGTGGTGCAGATCCTGA-3' 5'-CGGTCTGGGAAAGTTACAG-3'	<i>Z. albicollis</i> : HQ589117 <i>S. vulgaris</i> : HQ589113
<i>MSTNb</i> *	5'-CAACTTTTACCCAAGGCTCCTC-3' 5'-AAAAATGGGTTACTCTG-3'	<i>Z. albicollis</i> : HQ589120 <i>S. vulgaris</i> : HQ589116
<i>MSTNd</i> *	5'-CAATGCCTACAGAGTGCATC-3' 5'-GTCGAGACCGAAATCTCTGC-3'	<i>Z. albicollis</i> : HQ589119 <i>S. vulgaris</i> : HQ589115
<i>MSTNe</i> *	5'-CACAATGCCTACAGATATCCTG-3' 5'-CGGTCTGGGAAAGTTACAG-3'	<i>Z. albicollis</i> : HQ589118 <i>S. vulgaris</i> : HQ589114
<i>IGF1</i> degenerate	5'-AArCCnACnGGGTATGG-3' 5'-CyTTTGGCATrTcNGrTrTG-3'	
<i>IGF1</i> * ( <i>Z. albicollis</i> )	5'-TCCAGCAGTAGACGCTTACATC-3' 5'-CGGTTTTATCGGAGCACAGT-3'	HQ599312
<i>IGF1</i> * ( <i>S. vulgaris</i> )	5'-ATCCAGCAGTAGACGCTTAC-3' 5'-TACATCTCCAGCCTCCTCAG-3'	HQ599316
<i>TLL1</i> degenerate	5'-GATGACTACAGACCAATG-3' 5'-AGGrGTGGCrCTGATTTTC-3'	
<i>TLL1</i> * ( <i>S. vulgaris</i> )	5'-AAATTCTGCGGTACAGAAGTG-3' 5'-GTGCAGCACAAATCCGTTC-3'	HQ599313

*MSTNa*, classical myostatin transcript; *MSTNb*, *MSTNd* and *MSTNe*, *myostatin* splice variants; *IGF1*, insulin-like growth factor 1; *TLL1*, tollid-like protein 1. \*Primers used for qPCR.

group of these birds was sampled immediately after this flight ('post-flight',  $N=15$ ), while another group was sampled after 2 days of recovery ('trained',  $N=32$ ). This last group was used to investigate the effect of training while avoiding the effects of acute exercise, but matching the total flight time of the post-flight group. A third group of starlings was not flown in the wind tunnel ('untrained',  $N=45$ ). Starlings of all three exercise regimes were fed diets differing in fatty acid composition as part of a study on the effects of diet on exercise performance (S.R.McW., unpublished). Preliminary analyses indicated no effect of diet on the expression of genes measured in the current study (ANOVA,  $P>0.187$  for all genes) so diet groups were pooled. Birds were killed by decapitation under brief isoflurane anaesthesia, and the left pectoralis and supracoracoideus muscles were removed, weighed fresh, frozen in liquid nitrogen and stored at  $-80^{\circ}\text{C}$ .

Birds were collected under Canadian Wildlife Service permits (CA 0168 and CA 0170) and a US Fish and Wildlife Service permit (MB75836401). Experimental procedures were approved by the University of Western Ontario Animal Care and Use Subcommittee (protocols 2005-060-08 and 2006-011-04).

### mRNA expression

cDNA complementary to mRNA was obtained from pectoralis muscle samples as previously described (McFarlan et al., 2009; Zajac, 2010). Briefly, RNA was extracted from  $\sim 100$  mg pectoralis muscle with TRIzol (Invitrogen, Burlington, ON, Canada) using a glass homogenizer; 5  $\mu\text{g}$  total RNA was reverse transcribed to create cDNA, which was stored at  $-80^{\circ}\text{C}$  until qPCR analysis.

We designed degenerate primers (supplied by Invitrogen) based on known sequences in mammals and birds to amplify coding regions of *myostatin*, *IGF1* and *TLL-1* (*TLL-1* was measured in starlings only; previous experiments had resulted in a shortage of cDNA material in the sparrows) (Table 1). These regions were amplified under the same conditions as for qPCR (see below). The product was electrophoresed on an agarose gel, and the appropriate bands were extracted, purified and then sequenced at the London

Regional Genomics Centre at the Robarts Research Institute, University of Western Ontario. During this process, we noted the presence of several bands that were amplified by our *myostatin* primers in both species, and we excised these bands from gels for sequencing.

We then designed specific primers for use in qPCR (Table 1). We verified that these primers amplified only their intended target sequences by confirming the presence of a single band in gel electrophoresis for each primer pair. We also extracted those bands from gels and had them sequenced to verify sequence identity.

We performed qPCR with a Rotor-Gene 6000 Real-Time Rotary Thermocycler (Corbett Life Science, Concorde, NSW, Australia). Reaction conditions were  $1\times$  reaction buffer,  $3.5\text{ mmol l}^{-1}$   $\text{MgCl}_2$ ,  $0.2\text{ mmol l}^{-1}$  dNTPs,  $0.25\text{ }\mu\text{mol l}^{-1}$  primers, 0.75 U Platinum Taq polymerase,  $0.7\times$  SYBR-Green I (all from Invitrogen), with  $1\text{ }\mu\text{l}$  cDNA (first diluted 1:4 in water) in  $20\text{ }\mu\text{l}$  reaction volume. The cycling conditions were  $95^{\circ}\text{C}$  for 10 min, then 45 cycles of  $95^{\circ}\text{C}$  for 10 s,  $56^{\circ}\text{C}$  for 15 s,  $72^{\circ}\text{C}$  for 20 s and  $83^{\circ}\text{C}$  for 0 s. Fluorescence of the samples was measured at the end of the  $83^{\circ}\text{C}$  (*myostatin* splice variant *MSTNd*) or  $72^{\circ}\text{C}$  (all others) point of each cycle. Samples with failed reactions were removed from analysis.

For each gene, samples were run in duplicate and the cycle threshold of each sample was compared with a calibrator that was present in every run. The calibrator was created from a pool of several conspecific birds' cDNA. We determined reaction efficiency for each gene using a serial dilution of the calibrator. Expression in each sample was calculated as  $\text{Efficiency}^{\Delta\text{Ct}}$ , where  $\Delta\text{Ct}$  is the cycle threshold of the calibrator minus the cycle threshold of the sample. We used *actin* and *GAPDH* (glyceraldehyde 3-phosphate dehydrogenase) as housekeeper genes for standardization of *myostatin*, *IGF1* and *TLL1* gene expression. Expression of these housekeeper genes was previously determined for all of our samples (McFarlan et al., 2009; Zajac, 2010) (E.R.P., unpublished). Data are reported as an expression ratio, which was calculated as the expression of each target gene divided by the geometric average expression of the two housekeeper genes (Vandesompele et al.,

2002). The results of this study were not substantially affected by removal of either of the housekeeper genes from this calculation.

### Statistics

Expression data were compared among groups using ANOVA and Tukey's *post hoc* tests. Linear regression was used to compare splice variant expression with myostatin expression. Residuals from this regression were compared using ANOVA to compare photoperiod treatments. ANCOVA was used with tarsus length or body mass as a covariate to evaluate differences in muscle size associated with migratory condition (white-throated sparrows) or exercise training (European starlings). Analyses were conducted using SYSTAT 10 (Systat Software Inc., Chicago, IL, USA). Nucleotide sequence alignments were conducted using basic local alignment search tool (BLAST) (Altschul et al., 1990).

## RESULTS

### Muscle size

Photoperiod-manipulated 'migrant' sparrows had flight muscles (dry mass) that were 8% greater than those of 'wintering' sparrows ( $F_{1,44}=7.192$ ,  $P=0.010$ ). When controlling for tarsus size, 'migrant' sparrows still had larger flight muscles ( $F_{1,43}=6.979$ ,  $P=0.011$ ). European starlings that were flight trained for 2 weeks were heavier and had heavier flight muscles than untrained birds, although this effect of exercise training on pectoral muscle mass was not significant once adjusted for the difference in body mass between the two groups (ANCOVA: full model  $F_{6,65}=13.8$ ;  $P<0.001$ ; relationship to body mass  $F_{1,70}=23.8$ ,  $P<0.001$ ; treatment  $F_{1,70}=3.1$ ,  $P=0.082$ ; U.B., unpublished).

### mRNA expression of myostatin, IGF1 and TLL1

In wild white-throated sparrows, there was no effect of season on either *myostatin* ( $F_{3,55}=1.112$ ,  $P=0.352$ ) or *IGF1* expression ( $F_{3,51}=1.813$ ,  $P=0.156$ ) (Fig. 1A). Removal of the highly variable autumn juveniles from the analyses did not change the significance of statistical tests ( $P>0.186$  for both genes). Body condition, measured as body mass divided by tarsus length, was not significantly related to either *IGF1* or *myostatin* expression within or across seasons ( $P>0.05$  for all comparisons). In the captive photoperiod manipulation, 'migratory' sparrows experiencing long days expressed *myostatin* at 3.2-fold higher levels compared with those on short days ( $F_{1,45}=15.44$ ,  $P<0.001$ ; Fig. 1B). They expressed *IGF1* at 5.1-fold higher levels compared with those on short days ( $F_{1,45}=2.424$ ,  $P<0.001$ ; Fig. 1B).

There was no difference in myostatin expression levels among European starlings in the three exercise treatment groups (Fig. 1C;  $F_{2,89}=2.990$ ,  $P=0.055$ ). *IGF1* expression varied significantly among treatment groups ( $F_{2,89}=3.749$ ,  $P=0.027$ ). *IGF1* expression was elevated 3.0-fold in starlings sampled immediately post-flight compared with untrained birds ( $P=0.045$ ) and was elevated 4.2-fold compared with trained birds ( $P=0.027$ ). *IGF1* expression in the trained group was not different from that in untrained starlings ( $P=0.906$ ). *TLL1* expression did not vary with exercise treatment ( $F_{2,88}=0.043$ ,  $P=0.958$ ).

### Splice variants of myostatin

In both study species we found several myostatin splice variants (Fig. 2), which have previously been reported in birds in GenBank, but most are not described in the literature. Here, we follow and extend the nomenclature for avian splice variants used in GenBank accession nos EU336991.1, EU336992.1, HM560620.1 and HM560621.1. The classical *myostatin* transcript (variant A; *MSTNa*;

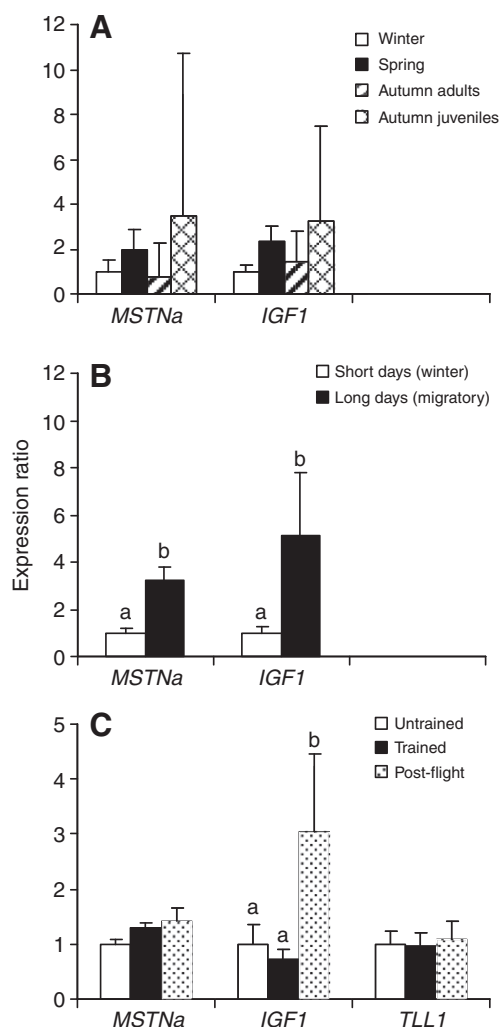

Fig. 1. mRNA expression (fold difference) of mediators of muscle growth in (A) wild white-throated sparrows in migratory and non-migratory seasons, (B) captive white-throated sparrows under photoperiodic manipulation, and (C) captive European starlings that were untrained, or trained and then measured either 2 days after a long flight ('trained') or immediately after a long flight ('post-flight') in a wind tunnel. For a given gene, bars without letters or that share letters indicate no significant difference ( $P>0.05$ ). Data are means + s.e.m. *MSTNa*: myostatin (typical variant); *IGF1*: insulin-like growth factor 1; *TLL1*: tolloid-like protein 1.  $N_{MSTN(winter)}=18$ ,  $N_{MSTN(spring)}=17$ ,  $N_{MSTN(autumn\ adults)}=12$ ,  $N_{MSTN(autumn\ juveniles)}=12$ ,  $N_{IGF1(winter)}=15$ ,  $N_{IGF1(spring)}=16$ ,  $N_{IGF1(autumn\ adults)}=12$ ,  $N_{IGF1(autumn\ juveniles)}=12$ ,  $N_{short\ days}=24$ ,  $N_{long\ days}=23$ ,  $N_{untrained}=45$  (*MSTN*, *IGF1*) or 44 (*TLL1*),  $N_{trained}=32$ ,  $N_{post-flight}=15$ .

Fig. 2) aligns well with published coding sequences for *myostatin* in chickens (*Gallus gallus*, 93% identity) and mammals, as does its predicted protein product, which contains the expected conserved cysteine residues, the RXXR furin cleavage site, and a metalloprotease cleavage site (Fig. 3). The splice variants E (*MSTNe*), D (*MSTNd*) and B (*MSTNb*) have increasingly larger sequences missing from exon 2 (Fig. 2), and the 5' splice site of all of these variants is the same as the 5' splice site of intron 1 of the classical *myostatin* transcript (*MSTNa*). The predicted protein products of *MSTNe* and *MSTNb* contain premature stop codons such that the mature myostatin peptide (located downstream of the RXXR site; coded in exon 3) is missing entirely. The *MSTNd* variant is spliced in-frame, such that 99 amino acid residues are missing from the propeptide compared with *MSTNa* (Fig. 3).

```

151
EUST MSTNa AACGATTATCACAATGCCTACAGAGTCTGATTTTCTTGTACAAATGGAGG
EUST MSTNb AACGATTATCACAATGCCTACAGAGT-----
EUST MSTNd AACGATTATCACAATGCCTACAGAGT-----
EUST MSTNe AACGATTATCACAATGCCTACAGAGT-----

EUST MSTNa GAAACCAAATGTTGCTTCTTTAAGTTTAGCTCTAAAATACAATATAAC
EUST MSTNb -----
EUST MSTNd -----
EUST MSTNe -----

EUST MSTNa AAAGTAGTAAAAGCACAATTGGATATACTTGAGCAAGTCCAAAAACC
EUST MSTNb -----
EUST MSTNd -----
EUST MSTNe -----

EUST MSTNa TACAACGGTGTTTGTGCAGATCCTGAGACTTATTAACCCTGAAAGATG
EUST MSTNb -----
EUST MSTNd -----
EUST MSTNe -----ATCCTGAGACTTATTAACCCTGAAAGATG

EUST MSTNa GCACAAGATATACTGGAATTCGATCTTTGAAACTTGACATGAACCCAGGC
EUST MSTNb -----
EUST MSTNd -----
EUST MSTNe GCACAAGATATACTGGAATTCGATCTTTGAAACTTGACATGAACCCAGGC

EUST MSTNa ACCGGTATTTGGCAGAGTATTGATGTGAAGACAGTGTGCAAAATGGCT
EUST MSTNb -----
EUST MSTNd -----
EUST MSTNe ACCGGTATTTGGCAGAGTATTGATGTGAAGACAGTGTGCAAAATGGCT

EUST MSTNa CAAACAGCCTGAATCCAATTTAGGCATCGAAATAAAAGCTTTTGATGAGA
EUST MSTNb -----GCATCGAAATAAAAGCTTTTGATGAGA
EUST MSTNd -----
EUST MSTNe CAAACAGCCTGAATCCAATTTAGGCATCGAAATAAAAGCTTTTGATGAGA

EUST MSTNa ACGGACGGAATCTTGCTGTAACCTTCCAGGACCGGGGGAAGATGGATTG
EUST MSTNb -----
EUST MSTNd -----
EUST MSTNe ACGGACGGAATCTTGCTGTAACCTTCCAGGACCGGGGGAAGATGGATTG

600
EUST MSTNa AACCATTTTTGGAGGTCAGAGTCACAGACACCCGAAACGGTCCCGCAG
EUST MSTNb AACCATTTTTGGAGGTCAGAGTCACAGACACCCGAAACGGTCCCGCAG
EUST MSTNd AACCATTTTTGGAGGTCAGAGTCACAGACACCCGAAACGGTCCCGCAG
EUST MSTNe AACCATTTTTGGAGGTCAGAGTCACAGACACCCGAAACGGTCCCGCAG
    
```

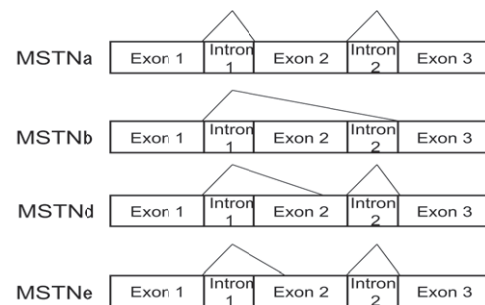

Fig. 2. Left, alignment of partial nucleotide sequences of cDNA for *myostatin* splice variants in European starlings. Numbers indicate the nucleotide number in the typical *myostatin* (*MSTNa*) partial coding sequence (HQ589113). Right, schematic diagram of *myostatin* splice variants in European starlings and white-throated sparrows; exon/intron locations are based on the review by Rodgers and Garikipati (Rodgers and Garikipati, 2008). Triangles indicate inferred splice locations for each variant.

We were interested in whether these alternative *myostatin* splice variants are merely mistakes of the splicing machinery or have functional significance. We therefore tested whether the expression of these variants (B, D and E) was correlated with expression of the ‘normal’ *myostatin* (*MSTNa*). We designed primers to amplify these splice variants (Table 1), and measured their expression levels in photoperiod-manipulated sparrows, as these birds had demonstrated the most dramatic differences in expression of *MSTNa*. Expression of the splice variants was significantly ( $P < 0.001$  for all variants) related to the expression of *MSTNa*, with  $R^2$  ranging from 0.58 (*MSTNb*) to 0.93 (*MSTNd*; Fig. 4). If the occurrence/prevalence of splice variants has some role in modulating the effects of the classical myostatin during Zugenruhe, one might expect that for a given level of *myostatin* (*MSTNa*) expression, splice variant expression would be higher or lower, depending on the photoperiod treatment. We therefore examined the residuals from the relationships between the splice variants and *MSTNa*. Residuals from this relationship did not differ significantly between the ‘winter’ and ‘migratory’ groups ( $P > 0.139$  for all variants, Fig. 4).

**DISCUSSION**

We have demonstrated increased expression of *myostatin* and *IGF1* mRNA in pectoralis muscles of captive sparrows that were photoperiod manipulated to be in a ‘migratory’ condition. These changes were accompanied by increased flight muscle mass that

was induced by photoperiodic manipulation. Further, we have demonstrated increased *IGF1* mRNA expression in starlings immediately after an acute bout of wind-tunnel flight.

**Exercise and the expression of *myostatin*, *TLL1* and *IGF1* mRNA**

Resistance training and endurance exercise can result in increased muscle size as muscles acclimate to increased workload (Roth et al., 2003; Walker et al., 2004; Willoughby, 2004; Martin and Johnston, 2005). Exercise and training have also been associated with decreased expression of *myostatin* mRNA and protein in humans (Roth et al., 2003; Raue et al., 2006; Louis et al., 2007) and rats (Matsakas et al., 2005; Matsakas et al., 2006; Heinemeier et al., 2007), although this finding has not been consistent. In response to overloading of the plantaris muscle in ground squirrels (*Callospermophilus lateralis*), muscle hypertrophy was observed without a change in the expression of *myostatin* mRNA (Choi et al., 2009). In other mammalian studies, muscle *myostatin* expression has paradoxically increased in response to training or overloading in skeletal or cardiac muscle (Sakuma et al., 2000; Willoughby, 2004; Matsakas et al., 2006; Jensky et al., 2007; Jensky et al., 2010). In rainbow trout (*Oncorhynchus mykiss*), Martin and Johnston found a significant decrease in myostatin protein in response to training, but the magnitude of the decrease was so small (6%) that they concluded myostatin played no more than a minor role in regulating

```

Gallus      ...EQAPNISR↓VIKQLLPKAPPLQELIDQYDVQRDDSSDGSL
MSTNa      ...EQAPNISR↓VIKQLLPKAPPLQELIDQYDVQRDDSSDGSL
MSTNb      ...EQAPNISR↓VIKQLLPKAPPLQELIDQYDVQRDDSSDGSL
MSTNd      ...EQAPNISR↓VIKQLLPKAPPLQELIDQYDVQRDDSSDGSL
MSTNe      ...EQAPNISR↓VIKQLLPKAPPLQELIDQYDVQRDDSSDGSL

Gallus      EDDDYHATTETIITMPTESDLVQMEGKPKCCFFKFSSKIQYN
MSTNa      EDDDYHATTETIITMPTESDLVQMEGKPKCCFFKFSSKIQYN
MSTNb      EDDDYHATTETIITMPTE*
MSTNd      EDDDYHATTETIITMPTEC-----
MSTNe      EDDDYHATTETIITMPTEYPETY*

Gallus      KVVKAQLWIYLRQVQKPTTFVQILRLIKPMKDGRYTRTGIRSL
MSTNa      KVVKAQLWIYLRQVQKPTTFVQILRLIKPMKDGRYTRTGIRSL
MSTNb      -----
MSTNd      -----
MSTNe      -----

Gallus      KLDMPNGTGIWQSIDVKTVLQNLKQPESNLGEIKAFDETGR
MSTNa      KLDMPNGTGIWQSIDVKTVLQNLKQPESNLGEIKAFDENG
MSTNb      -----
MSTNd      -----IEIKAFDENG
MSTNe      -----

Gallus      DLAVTFPGPGEDGLNPFLEVRVTDTPKRSRRDFGLDCDEHSTE
MSTNa      NLAVTFPGPGEDGLNPFLEVRVTDTPKRSRRDFGLDCDEHSTE
MSTNb      -----
MSTNd      NLAVTFPGPGEDGLNPFLEVRVTDTPKRSRRDFGLDCDEHSTE
MSTNe      -----

Gallus      SRCRYPLTVDFAFGWDWIIAPKRYKANYCSGCEEFVFLQ..
MSTNa      SRCRYPLTVDFAFGWDWIIAPKRYKANYCSGCEEFVFLQ..
MSTNb      -----
MSTNd      SRCRYPLTVDFAFGWDWIIAPKRYKANYCSGCEEFVFLQ..
MSTNe      -----

```

Fig. 3. Partial predicted amino acid sequence of myostatin from *Gallus gallus* (accession no. NM\_001001461.1) and myostatin splice variants from *Stumus vulgaris* and *Zonotrichia albicollis* (MSTNa-e; the two species had identical splice variants and predicted amino acid sequences in the region shown). Highlighted are conserved cysteine residues, the conserved aspartate site of metalloprotease cleavage (arrow) and the conserved RXXR furin cleavage site. Asterisks indicate premature stop codons in the MSTNb and MSTNe splice variants.

muscle mass after exercise (Martin and Johnston, 2005). Our results from starlings exercising in a wind tunnel demonstrate training-induced muscle hypertrophy, yet no decrease in *myostatin* mRNA expression in response to either acute exercise or 2 weeks of flight training; in fact, *myostatin* mRNA expression trended higher immediately after a long-duration flight compared with trained and untrained animals. Further, *TLI1*, a metalloprotease important in cleaving the propeptide to produce the mature myostatin protein, did not show elevated mRNA expression due to acute exercise or training. These data are not consistent with myostatin being an important regulator of muscle mass during exercise in starlings. However, we note the possibility that myostatin protein levels respond differently, or that changes in *myostatin* mRNA occur early in exercise training but return to baseline levels after 2 weeks of training.

In contrast, *IGF1* expression was substantially increased immediately following an exercise bout. Previous work in mammals has demonstrated that *IGF1* expression in muscles is induced by muscle contraction and during compensatory hypertrophy (DeVol et al., 1990; Heinemeier et al., 2007; Choi et al., 2009). IGF1 is known to stimulate protein synthesis in myocytes and also satellite cell proliferation, leading to hypertrophy (Rennie et al., 2004). Interestingly, trained starlings did not exhibit elevated *IGF1* mRNA expression when measured on a day without flight exercise. Thus, training did not result in sustained expression of *IGF1* mRNA at elevated levels. We do not know the effects of exercise on IGF1

protein levels, but it is possible that transient increases in *IGF1* mRNA during training bouts are enough to cause sustained increases in IGF1 protein levels, which can then mediate an augmentation in muscle size.

#### Seasonal regulation of muscle mass in white-throated sparrows

We found that seasonally appropriate increases in flight muscle size could be induced by manipulation of photoperiod. This complements earlier reports of a circannual rhythm that regulates pectoralis muscle size endogenously without training in the long-distance migrating red knot (*Calidris canutus*) (Dietz et al., 1999; Vézina et al., 2007). This increase in muscle mass in sparrows was accompanied by elevated mass-specific oxidative capacity (Zajac, 2010). An endogenously controlled increase in flight muscle mass is analogous to pre-migratory preparation, or a general seasonal shift that could have effects throughout the migratory period. We admit the possibility, however, that the increased muscle mass could also be caused by increased nightly activity.

Many species undergo seasonal, predictable shifts in muscle size. These shifts can be endogenously controlled or influenced by muscle activity. Investigations in moulting lobsters (MacLea et al., 2010), hibernating ground squirrels (Nowell et al., 2011) and overwintering songbirds (Swanson et al., 2009) indicate that *myostatin* and *IGF1* are involved in adult seasonal muscle phenotypic flexibility. Migration similarly involves seasonal changes in a suite of traits (organ size, hyperphagia, orientation, etc.) that are under the control of endogenous rhythms entrained by photoperiod (Dingle, 1996). These coordinated changes afford birds phenotypic flexibility that is preparatory to, as opposed to merely responsive to, predictable seasonal changes in environment/life history stage. The results of our photoperiod manipulation experiment indicate that sparrows prepare for migration by increasing expression of both *myostatin* and *IGF1* (Fig. 1B). We cannot rule out a possible 'training effect' from increased nightly activity. However, training had no effect on *IGF1* mRNA in starlings, and *myostatin* expression was significantly increased in long day 'migratory' sparrows, whereas *myostatin* expression was unchanged by exercise in starlings. While caution is necessary in comparing across species, together our results suggest that the photoperiod-induced effect is driven by endogenous rhythms acting on the muscles and not by changes in muscle use.

The increase in *IGF1* expression in photo-stimulated sparrows is consistent with its known role in promoting muscle growth and protein synthesis. However, the increase in *myostatin* expression in long-day 'migratory' sparrows was unexpected, as myostatin is usually associated with decreased muscle mass. It is difficult to infer what effect this had on our birds, particularly in the absence of protein abundance data. The simultaneous upregulation of both anabolic and catabolic mediators seems futile, but could be important to muscle remodelling during the migratory period. Increased protein turnover (i.e. higher synthesis and degradation) occurred during muscle remodelling in response to muscle contraction in rats (Termin and Pette, 1992) and during experimentally induced moulting in land crabs (Covi et al., 2010), and higher protein turnover can occur during hypertrophy in response to exercise (Goldspink, 1991) (but see Bauchinger et al., 2010). Guernec and colleagues found increases in both *IGF1* and *myostatin* expression during a period of growth in chicks, and they hypothesized that the ratio of *IGF1* to *myostatin* expression may be important in determining overall muscle growth (Guernec et al., 2003). Elevated protein turnover might also be important for responding to muscle damage, which can occur in wild migrants (Guglielmo et al., 2001).

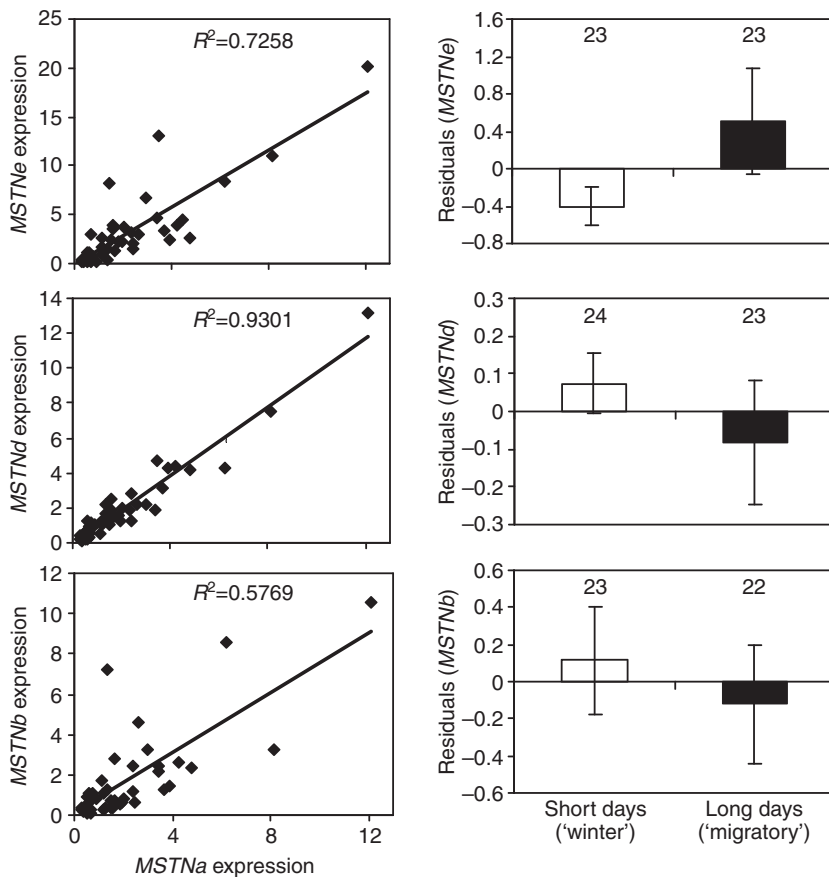

Fig. 4. Left, relationship between expression of *myostatin* splice variants (*MSTNb*, *MSTNd* and *MSTNe*) and the expression of the typical *myostatin* (*MSTNa*) in captive white-throated sparrows. Right, residuals from these relationships for sparrows that were photoperiod manipulated to experience short or long days. There were no significant differences ( $P>0.05$ ) between short and long day groups for the residuals of any of the variants. Data are means  $\pm$  s.e.m. Numbers above bars indicate sample sizes.

Another possible explanation could lie in the different time courses of mRNA expression for the two genes. For example, *IGF1* expression could increase first, resulting in increased muscle size, while *myostatin* mRNA levels could increase later to oppose the effects of *IGF1* and reach a new steady state at which muscle size is greater. Such a scenario could be tested with a more detailed time course of measurements.

In mammals, myostatin is known to affect adipose tissue. Myostatin knockout mice have reduced adiposity (Lin et al., 2002; McPherron and Lee, 2002), which could result from direct effects of myostatin acting on receptors located at adipocytes or could be an indirect effect of the energetic draw from increased musculature, and recent evidence suggests the latter mechanism may be dominant in adult mice (Guo et al., 2009). Nonetheless, if myostatin produced in muscles can increase adiposity by direct signalling in birds, this could represent another explanation for elevated *myostatin* mRNA in photo-stimulated sparrows, which must gain fat mass in preparation for migration.

Thyroid hormone, growth hormone, testosterone and glucocorticoids have been implicated in coordinating migration-related changes to physiology and behavior (Wingfield et al., 1990; Tsioura et al., 1999). These seasonal shifts in hormones could coordinate changes in muscle size by regulating muscular transcription of *IGF1* and *myostatin*. Growth hormone and testosterone can induce *IGF1* transcription (DeVol et al., 1990; Brill et al., 2002), although growth hormone is not as strong an elicitor of extrahepatic *IGF1* transcription in chickens as it is in mammals (Rosselot et al., 1995; Tanaka et al., 1996). Further, growth hormone inhibits, while glucocorticoids increase muscle *myostatin* transcription in mammals (Liu et al., 2003; Ma et al., 2003). Future

studies should test the effects of these hormones on the expression of muscle growth factors in wild birds. Changes in growth factor receptor density could also mediate the migratory muscle size response; glucocorticoid receptor density changed during migration in white-crowned sparrows (*Z. leucophrys*) (Landys et al., 2004a).

Despite the changes to transcription that were induced by photoperiod, we found no significant variation in *myostatin* or *IGF1* expression with season in the wild sparrows. This may be because of greater variability in wild birds compared with controlled laboratory conditions. Birds we caught at migratory stopover may have just completed a migratory flight and still be in a catabolic mode, while others may have just started rebuilding muscle or been rebuilding muscle for several days. We did not detect any effect of body condition (measured as body mass/tarsus) on *myostatin* or *IGF1* expression, although this metric may not have accurately captured refuelling status. A worthwhile avenue of future investigation would be to track *myostatin* and *IGF1* mRNA and protein levels over the course of a migratory stopover. It is worth noting the high *myostatin* and *IGF1* mRNA expression and variability in autumn juveniles in comparison to autumn adults, which could reflect higher protein turnover during development.

#### Splice variants of myostatin and their function in birds

In both species examined, we found several splice variants of *myostatin* that have been reported previously for birds in GenBank and/or in the literature. *MSTNa* is the classical *myostatin* transcript. *MSTNb* and *MSTNd* have been reported in GenBank for mallards (*Anas platyrhynchos*; EU333692.1 and HM560621.1). *MSTNe* has been reported (with the name *scMSTN*) in chickens (FJ860018.1) and its expression in chickens has been noted (Moon et al., 2005;

Castelhana-Barbosa et al., 2005). Additionally, a variant C (*MSTNc*) is reported for mallards (HM560620.1) that has the same 5' splice site as the other variants and a 3' splice site located in exon 2. Although investigators working in other species of birds have not yet reported these splice variants, this does not indicate their absence in those species, as investigators might not sequence bands of non-target sizes, and expression levels of splice variants may be low and therefore go undetected. Given the shared 5' splice site of all these variants (indicating a common alternative splicing mechanism), and the presence of similar splice variants in phylogenetically distant species, we suggest that some or all of these splice variants could be present in all birds, or at least in all the neognathae. Splice variants of *myostatin* in other taxa (Garikipati et al., 2007; Covi et al., 2008) differ in structure from those found in birds.

The existence of the same splice variants in distantly related avian species suggests functionality. Previous authors have noted that the truncated transcript of *MSTNe* could produce a propeptide without producing the C-terminal sequence that ultimately becomes the mature myostatin protein (Castelhana-Barbosa et al., 2005), a feature also noted in the alternatively spliced transcripts of land crabs (*Gecarcinus lateralis*) (Covi et al., 2008). Thus, increasing the percentage of *myostatin* transcripts that are alternatively spliced could be a mechanism to down-regulate the number of functional, mature myostatin proteins that are produced. Further, it has been suggested that the production of the propeptide alone *via* these alternative transcripts could inhibit mature myostatin peptides that are already formed (Castelhana-Barbosa et al., 2005; Rodgers and Garikipati, 2008), a possibility reinforced by a study of overexpression of the propeptide in mice (Zhao et al., 2009). Two of the splice variants we found (*MSTNb* and *MSTNe*) end in premature stop codons before the C-terminal section encoding the mature myostatin protein, and the third (*MSTNd*) lacks a large stretch of amino acids that we can only speculate would hinder normal function or production of the mature protein. We note, however, that the premature stop codons of *MSTNb* and *MSTNe* exclude not only the C-terminal sequence but also a large stretch of the propeptide from being translated, and thus might alter the myostatin-inhibiting properties of the propeptide as well.

All of the known splice variants in birds have the same 5' splice site, which is located at the 5' end of intron 1 of the classical *myostatin* transcript (*MSTNa*). Thus, it is possible that these splice variants are merely mistakes arising during spliceosome processing, whereby extra portions of mRNA (part or all of exon 2) are accidentally removed from a certain percentage of transcripts. This is consistent with our data, as expression of the alternative transcripts was linearly related to expression of the classical *myostatin* transcript. Further, we investigated residuals from this relationship with the expectation that for a given level of typical *myostatin* expression, expression of variants would be greater in one of the photoperiod groups if the variants have some functional meaning. However, residuals did not differ between treatment groups, indicating no functional role for alternatively spliced transcripts, at least in this Zugunruhe context. While our data provide no evidence for functionality of these splice variants, the apparently broad distribution of these variants in birds and the lack of similar variants in non-avian species warrant further attention and investigation into their possible function.

### CONCLUSIONS

These results demonstrate that adult birds can adjust muscle size in response to exercise and suggest that birds adjust muscle size in anticipation of increased workload (migratory preparation). Our results are consistent with *IGF1* mediating this phenotypic flexibility

of muscle size in both contexts. The importance of *myostatin* is less clear; its paradoxical increase in expression during Zugunruhe may indicate increased protein turnover. Expression patterns of splice variants of *myostatin* do not further inform this question. Further refinement of our understanding of these processes will be derived from investigation of myostatin and IGF1 protein abundance, research on the seasonal hormonal signals triggering expression of *IGF1*, and finer scale time courses of expression patterns in both wild and captive birds.

### ACKNOWLEDGEMENTS

Michelle Boyles and Lillie Langlois provided organizational and technical assistance, as well as flight training for starlings. Collection and field site assistance was provided by Mary Gartshore, Peter Carson, Frank Moore, Paul Hammil and Quentin Hays. Assistance with animal care was provided by Wayne Bezner Kerr and Michaela Rebuli. David Swanson and Boris Sabirzhanov kindly provided us with their house sparrow sequences. We thank Dillon Chung, Yanina Sarquis Adamson and Lovesha Sivanantharajah for laboratory assistance. We appreciate the insightful comments of two anonymous reviewers. Funding was provided to S.R.McW. by the US National Science Foundation (IOS-0748349), US Department of Agriculture (RIAES-538748), and the University of Rhode Island. Funding was provided to C.G.G. by a National Sciences and Engineering Research Council of Canada Discovery Grant, and a New Initiatives grant from the Canada Foundation for Innovation and the Ontario Research Fund.

### REFERENCES

- Adams, G. R. (1998). Role of insulin-like growth factor-I in the regulation of skeletal muscle adaptation to increased loading. *Exerc. Sport Sci. Rev.* **26**, 31-60.
- Altschul, S. F., Gish, W., Miller, W., Myers, E. W. and Lipman, D. J. (1990). Basic local alignment search tool. *J. Mol. Biol.* **215**, 403-410.
- Amirouche, A., Durieux, A.-C., Banzet, S., Koulmann, N., Bonnefoy, R., Mouret, C., Bigard, X., Peinnequin, A. and Freyssenet, D. (2009). Down-regulation of Akt/mammalian target of rapamycin signaling pathway in response to myostatin overexpression in skeletal muscle. *Endocrinology* **150**, 286-294.
- Battley, P. F. and Piersma, T. (1997). Body composition of Lesser Knots (*Calidris canutus rogersi*) preparing to take off on migration from northern New Zealand. *Notornis* **44**, 137-150.
- Battley, P. F., Piersma, T., Dietz, M. W., Tang, S., Dekinga, A. and Hulsman, K. (2000). Empirical evidence for differential organ reductions during trans-oceanic bird flight. *Proc. R. Soc. Lond. B* **267**, 191-195.
- Bauchinger, U. and Biebach, H. (2001). Differential catabolism of muscle protein in garden warblers (*Sylvia borin*): flight and leg muscle act as a protein source during long-distance migration. *J. Comp. Physiol. B* **171**, 293-301.
- Bauchinger, U. and Biebach, H. (2006). Transition between moult and migration in a long-distance migratory passerine: organ flexibility in the African wintering area. *J. Ornithol.* **147**, 266-273.
- Bauchinger, U. and McWilliams, S. R. (2010). Extent of phenotypic flexibility during long-distance flight is determined by tissue-specific turnover rates: a new hypothesis. *J. Avian Biol.* **41**, 603-608.
- Bauchinger, U., Wohlmann, A. and Biebach, H. (2005). Flexible remodeling of organ size during spring migration of the garden warbler (*Sylvia borin*). *Zoology* **108**, 97-106.
- Bauchinger, U., Keil, J., McKinney, R. A., Starck, J. M. and McWilliams, S. R. (2010). Exposure to cold but not exercise increases carbon turnover rates in specific tissues of a passerine. *J. Exp. Biol.* **213**.
- Biebach, H. (1998). Phenotypic organ flexibility in Garden Warblers *Sylvia borin* during long-distance migration. *J. Avian Biol.* **29**, 529-535.
- Brill, K. T., Weltman, A. L., Gentili, A., Patrie, J. T., Fryburg, D. A., Hanks, J. B., Urban, R. J. and Veldhuis, J. D. (2002). Single and combined effects of growth hormone and testosterone administration on measures of body composition, physical performance, mood, sexual function, bone turnover, and muscle gene expression in healthy older men. *J. Clin. Endocrinol. Metab.* **87**, 5649-5657.
- Butler, P. J. and Turner, D. L. (1988). Effect of training on maximal oxygen uptake and aerobic capacity of locomotory muscles in tufted ducks, *Aythya fuligula*. *J. Physiol.* **401**, 347-359.
- Cabe, P. R. (1993). European Starling (*Sturnus vulgaris*). In *The Birds of North America*, No. 48 (ed. A. Poole and F. Gill). Philadelphia: The Academy of Natural Sciences and The American Ornithologist's Union.
- Castelhana-Barbosa, E. C., Gabriel, J. E., Álvares, L. E., Monteiro-Vitorello, C. B. and Coutinho, L. L. (2005). Temporal and spatial expression of the myostatin gene during chicken embryo development. *Growth Dev. Aging* **69**, 3-12.
- Choi, H., Selpides, P.-J. I., Nowell, M. M. and Rourke, B. C. (2009). Functional overload in ground squirrel plantaris muscle fails to induce myosin isoform shifts. *Am. J. Physiol. Regul. Integr. Comp. Physiol.* **297**, R578-R586.
- Covi, J. A., Kim, H.-W. and Mykles, D. L. (2008). Expression of alternatively spliced transcripts for a myostatin-like protein in the blackback land crab, *Gecarcinus lateralis*. *Comp. Biochem. Physiol.* **150A**, 423-430.
- Covi, J. A., Bader, B. D., Chang, E. S. and Mykles, D. L. (2010). Molt cycle regulation of protein synthesis in skeletal muscle of the blackback land crab, *Gecarcinus lateralis*, and the differential expression of a myostatin-like factor during atrophy induced by molting or unweighting. *J. Exp. Biol.* **213**, 172-183.
- DeVol, D. L., Rotwein, P., Sadow, J. L., Novakofski, J. and Bechtel, P. J. (1990). Activation of insulin-like growth factor gene expression during work-induced skeletal muscle growth. *Am. J. Physiol. Endocrinol. Metab.* **259**, E89-E95.



- Dietz, M. W., Piersma, T. and Dekinga, A. (1999). Body-building without power training: endogenously regulated pectoral muscle hypertrophy in confined shorebirds. *J. Exp. Biol.* **202**, 2831-2837.
- Dingle, H. (1996). *Migration: The Biology of Life on the Move*. New York: Oxford University Press.
- Driedzic, W. R., Crowe, H. L., Hicklin, P. W. and Sephton, D. H. (1993). Adaptations in pectoralis muscle, heart mass, and energy metabolism during premigratory fattening in semipalmated sandpipers (*Calidris pusilla*). *Can. J. Zool.* **71**, 1602-1608.
- Duclos, M. J. (2005). Insulin-like growth factor-I (IGF-1) mRNA levels and chicken muscle growth. *J. Physiol. Pharmacol.* **56 Suppl.** **3**, 25-35.
- Engel, S., Biebach, H. and Visser, G. H. (2006). Metabolic costs of avian flight in relation to flight velocity: a study in rose coloured starlings (*Sturnus roseus*, Linnaeus). *J. Comp. Physiol. B* **176**, 415-427.
- Evans, P. R., Davidson, N. C., Uttley, J. D. and Evans, R. D. (1992). Premigratory hypertrophy of flight muscles: an ultrastructural study. *Ornis Scand.* **23**, 238-243.
- Garikipati, D. K., Gahr, S. A., Roalson, E. H. and Rodgers, B. D. (2007). Characterization of rainbow trout myostatin-2 genes (rMSTN-2a and -2b): genomic organization, differential expression, and pseudogenization. *Endocrinology* **148**, 2106-2115.
- Gerson, A. R. and Guglielmo, C. G. (2011). House sparrows (*Passer domesticus*) increase protein catabolism in response to water restriction. *Am. J. Physiol. Regul. Integr. Comp. Physiol.* **300**, R925-R930.
- Goldspink, D. F. (1991). Exercise-related changes in protein turnover in mammalian striated muscle. *J. Exp. Biol.* **160**, 127-148.
- Guernec, A., Berri, C., Chevalier, B., Wacrenier-Cere, N., Le Bihan-Duval, E. and Duclos, M. J. (2003). Muscle development, insulin-like growth factor-I and myostatin mRNA levels in chickens selected for increased breast muscle yield. *Growth Horm. IGF Res.* **13**, 8-18.
- Guglielmo, C. G., Piersma, T. and Williams, T. D. (2001). A sport-physiological perspective on bird migration: evidence for flight-induced muscle damage. *J. Exp. Biol.* **204**, 2683-2690.
- Guo, T., Jou, W., Chanturiya, T., Portas, J., Gavrilova, O. and McPherron, A. C. (2009). Myostatin inhibition in muscle, but not adipose tissue, decreases fat mass and improves insulin sensitivity. *PLoS ONE* **4**, e4937.
- Heinemeier, K. M., Olesen, J. L., Schjerling, P., Haddad, F., Langberg, H., Baldwin, K. M. and Kjaer, M. (2007). Short-term strength training and the expression of myostatin and IGF-1 isoforms in rat muscle and tendon: differential effects of specific contraction types. *J. Appl. Physiol.* **102**, 573-581.
- Jensky, N. E., Sims, J. K., Rice, J. C., Dreyer, H. C. and Schroeder, E. T. (2007). The influence of eccentric exercise on mRNA expression of skeletal muscle regulators. *Eur. J. Appl. Physiol.* **101**, 473-480.
- Jensky, N. E., Sims, J. K., Dieli-Conwright, C. M., Sattler, F. R., Rice, J. C. and Schroeder, E. T. (2010). Exercise does not influence myostatin and follistatin messenger RNA expression in young women. *J. Strength Cond. Res.* **24**, 522-530.
- Kim, Y. S., Bobbili, N. K., Lee, Y. K., Jin, H. J. and Dunn, M. A. (2007). Production of a polyclonal anti-myostatin antibody and the effects of in ovo administration of the antibody on posthatch broiler growth and muscle mass. *Poult. Sci.* **86**, 1196-1205.
- King, J. R. and Farnier, D. S. (1963). The relationship of fat deposition to Zugunruhe and migration. *Condor* **65**, 200-223.
- Landys, M. M., Ramenofsky, M., Guglielmo, C. and Wingfield, J. C. (2004a). The low-affinity glucocorticoid receptor regulates feeding and lipid breakdown in the migratory Gambel's white-crowned sparrow *Zonotrichia leucophrys gambelli*. *J. Exp. Biol.* **207**, 143-154.
- Landys, M. M., Wingfield, J. C. and Ramenofsky, M. (2004b). Plasma corticosterone increases during migratory restlessness in the captive white-crowned sparrow *Zonotrichia leucophrys gambelli*. *Horm. Behav.* **46**, 574-581.
- Landys-Ciannelli, M. M., Piersma, T. and Jukema, J. (2003). Strategic size changes of internal organs and muscle tissue in the bar-tailed godwit during fat storage on a spring stopover site. *Funct. Ecol.* **17**, 151-159.
- Lee, S.-J. (2004). Regulation of muscle mass by myostatin. *Annu. Rev. Cell Dev. Biol.* **20**, 61-86.
- Lin, J., Arnold, H. B., Della-Fera, M. A., Azain, M. J., Hartzell, D. L. and Baile, C. A. (2002). Myostatin knockout in mice increases myogenesis and decreases adipogenesis. *Biochem. Biophys. Res. Commun.* **291**, 701-706.
- Lindström, Å., Kvist, A., Piersma, T., Dekinga, A. and Dietz, M. W. (2000). Avian pectoral muscle size rapidly tracks body mass changes during flight, fasting and fuelling. *J. Exp. Biol.* **203**, 913-919.
- Liu, W., Thomas, S. G., Asa, S. L., Gonzalez-Cadavid, N., Bhasin, S. and Ezzat, S. (2003). Myostatin is a skeletal muscle target of growth hormone anabolic action. *J. Clin. Endocrinol. Metab.* **88**, 5490-5496.
- Louis, E., Raue, U., Yang, Y., Jemiolo, B. and Trappe, S. (2007). Time course of proteolytic, cytokine, and myostatin gene expression after acute exercise in human skeletal muscle. *J. Appl. Physiol.* **103**, 1744-1751.
- Ma, K., Mallidis, C., Bhasin, S., Mahabadi, V., Artaza, J., Gonzalez-Cadavid, N., Arias, J. and Salehian, B. (2003). Glucocorticoid-induced skeletal muscle atrophy is associated with upregulation of myostatin gene expression. *Am. J. Physiol. Endocrinol. Metab.* **285**, E363-E371.
- MacLea, K. S., Covi, J. A., Kim, H.-W., Chao, E., Medler, S., Chang, E. S. and Mykles, D. L. (2010). Myostatin from the American lobster, *Homarus americanus*: cloning and effects of molting on expression in skeletal muscles. *Comp. Biochem. Physiol.* **157A**, 328-337.
- Marsh, R. L. (1984). Adaptations of the gray catbird *Dumetella carolinensis* to long-distance migration: flight muscle hypertrophy associated with elevated body mass. *Physiol. Zool.* **57**, 105-117.
- Martin, C. I. and Johnston, I. A. (2005). The role of myostatin and the calcineurin-signalling pathway in regulating muscle mass in response to exercise training in the rainbow trout *Oncorhynchus mykiss* Walbaum. *J. Exp. Biol.* **208**, 2083-2090.
- Matsakas, A., Friedel, A., Hertrampf, T. and Diel, P. (2005). Short-term endurance training results in a muscle-specific decrease of myostatin mRNA content in the rat. *Acta Physiol. Scand.* **183**, 299-307.
- Matsakas, A., Bozzo, C., Cacciani, N., Caliaro, F., Reggiani, C., Mascarello, F. and Patrino, M. (2006). Effect of swimming on myostatin expression in white and red gastrocnemius muscle and in cardiac muscle of rats. *Exp. Physiol.* **91**, 983-994.
- McFarlan, J. T., Bonen, A. and Guglielmo, C. G. (2009). Seasonal upregulation of fatty acid transporters in flight muscles of migratory white-throated sparrows (*Zonotrichia albicollis*). *J. Exp. Biol.* **212**, 2934-2940.
- McFarland, D. C., Velleman, S. G., Pesall, J. E. and Liu, C. (2007). The role of myostatin in chicken (*Gallus domesticus*) myogenic satellite cell proliferation and differentiation. *Gen. Comp. Endocrinol.* **151**, 351-357.
- McFarlane, C., Plummer, E., Thomas, M., Henneby, A., Ashby, M., Ling, N., Smith, H., Sharma, M. and Kambadur, R. (2006). Myostatin induces cachexia by activating the ubiquitin proteolytic system through an NF-κB-independent, FoxO1-dependent mechanism. *J. Cell. Physiol.* **209**, 501-514.
- McPherron, A. C. and Lee, S.-J. (2002). Suppression of body fat accumulation in myostatin-deficient mice. *J. Clin. Invest.* **109**, 595-601.
- McPherron, A. C., Lawler, A. M. and Lee, S.-J. (1997). Regulation of skeletal muscle mass in mice by a new TGF-β superfamily member. *Nature* **387**, 83-90.
- Moon, Y. S., Lee, H. G., Yin, Y. H., Jin, X., Hong, Z. S., Cho, J. S., Kim, S. C., You, S. K., Jin, D. I., Han, J. Y. et al. (2005). Effect of maternal passive autoimmunization against myostatin on growth performance in chickens. *Asian-Australas. J. Anim. Sci.* **18**, 1017-1021.
- Nowell, M. M., Choi, H. and Rourke, B. C. (2011). Muscle plasticity in hibernating ground squirrels (*Spermophilus lateralis*) is induced by seasonal, but not low-temperature, mechanisms. *J. Comp. Physiol. B* **181**, 147-164.
- Piersma, T., Gudmundsson, G. A. and Lilliendahl, K. (1999). Rapid changes in the size of different functional organ and muscle groups during refueling in a long-distance migrating shorebird. *Physiol. Biochem. Zool.* **72**, 405-415.
- Pyle, P. (1997). *Identification Guide to North American birds: Part 1*. Bolinas, CA: Slate Creek Press.
- Raue, U., Silvka, D., Jemiolo, B., Hollon, C. and Trappe, S. (2006). Myogenic gene expression at rest and after a bout of resistance exercise in young (18-30 yr) and old (80-89 yr) women. *J. Appl. Physiol.* **101**, 53-59.
- Rennie, M. J., Wackerhage, H., Spangenburg, E. E. and Booth, F. W. (2004). Control of the size of the human muscle mass. *Annu. Rev. Physiol.* **66**, 799-828.
- Rodgers, B. D. and Garikipati, D. K. (2008). Clinical, agricultural, and evolutionary biology of myostatin: a comparative review. *Endocr. Rev.* **29**, 513-534.
- Rosselot, G., McMurtry, J. P., Vasilatos-Younkens, R. and Czerwinski, S. (1995). Effect of exogenous chicken growth hormone (cGH) administration on insulin-like growth factor-I (IGF-I) gene expression in domestic fowl. *Mol. Cell. Endocrinol.* **114**, 157-166.
- Roth, S. M., Martel, G. F., Ferrel, R. E., Metter, E. J., Hurley, B. F. and Rogers, M. A. (2003). Myostatin gene expression is reduced in humans with heavy-resistance strength training: a brief communication. *Exp. Biol. Med.* **228**, 706-709.
- Sakuma, K., Watanabe, K., Sano, M., Uramoto, I. and Totsuka, T. (2000). Differential adaptation of growth and differentiation factor 8/myostatin, fibroblast growth factor 6 and leukemia inhibitory factor in overloaded, regenerating and denervated rat muscles. *Biochim. Biophys. Acta* **1497**, 77-88.
- Sato, F., Kurokawa, M., Yamauchi, N. and Hattori, M.-a. (2006). Gene silencing of myostatin in differentiation of chicken embryonic myoblasts by small interfering RNA. *Am. J. Physiol. Cell Physiol.* **291**, C538-C545.
- Swanson, D. L., Sabirzhanov, B., VandeZande, A. and Clark, T. G. (2009). Seasonal variation of myostatin gene expression in pectoralis muscle of house sparrows (*Passer domesticus*) is consistent with a role in regulating thermogenic capacity and cold tolerance. *Physiol. Biochem. Zool.* **82**, 121-128.
- Tanaka, M., Hayashida, Y., Sakaguchi, K., Ohkubo, T., Wakita, M., Hoshino, S. and Nakashima, K. (1996). Growth hormone-independent expression of insulin-like growth factor I messenger ribonucleic acid in extrahepatic tissues of the chicken. *Endocrinology* **137**, 30-34.
- Taylor, W. E., Bhasin, S., Artaza, J., Byhower, F., Azam, M., Willard, D. H., Jr, Kull, F. C., Jr and Gonzalez-Cadavid, N. (2001). Myostatin inhibits cell proliferation and protein synthesis in C<sub>2</sub>C<sub>12</sub> muscle cells. *Am. J. Physiol. Endocrinol. Metab.* **280**, E221-E228.
- Termin, A. and Pette, D. (1992). Changes in myosin heavy-chain isoform synthesis of chronically stimulated rat fast-twitch muscle. *Eur. J. Biochem.* **204**, 569-573.
- Tsipoura, N., Scanes, C. G. and Burger, J. (1999). Corticosterone and growth hormone levels in shorebirds during spring and fall migration stopover. *J. Exp. Biol.* **284**, 645-651.
- Vandesompele, J., De Preter, K., Pattyn, F., Poppe, B., Van Roy, N., De Paepe, A. and Speleman, F. (2002). Accurate normalization of real-time quantitative RT-PCR data by geometric averaging of multiple internal control genes. *Genome Biol.* **3**, Research0034.1-Research0034.11.
- Vézina, F., Jalvingh, K. M., Dekinga, A. and Piersma, T. (2007). Thermogenic side effects to migratory predisposition in shorebirds. *Am. J. Physiol. Regul. Integr. Comp. Physiol.* **292**, R1287-R1297.
- Walker, K. S., Kambadur, R., Sharma, M. and Smith, H. K. (2004). Resistance training alters plasma myostatin but not IGF-1 in healthy men. *Med. Sci. Sports Exerc.* **36**, 787-793.
- Willoughby, D. S. (2004). Effects of heavy resistance training on myostatin mRNA and protein expression. *Med. Sci. Sports Exerc.* **36**, 574-582.
- Wingfield, J. C., Schwabl, H. and Mattocks, P. W., Jr (1990). Endocrine mechanisms of migration. In *Bird Migration: Physiology and Ecophysiology* (ed. E. Gwinner), pp. 232-256. Berlin: Springer-Verlag.
- Zajac, D. M. (2010). Control of muscle fatty acid oxidation capacity and fatty acid transport proteins in migratory birds: effects of photoperiod and leptin, MSc thesis, University of Western Ontario London, ON, Canada.
- Zhao, B., Li, E. J., Wall, R. J. and Yang, J. (2009). Coordinated patterns of gene expressions for adult muscle build-up in transgenic mice expressing myostatin propeptide. *BMC Genomics* **10**, 305.